

Research Article

Evaluation of salt tolerance indices in contrast to rice (*Oryza sativa* L.) cultivars and mutants

Farhad Bagheri¹, Hemmatollah Pirdashti*², Gorban Ali Nematzadeh³, Yasser Yaghoubian¹

¹ Department of Agronomy, Sari Agricultural Sciences and Natural Resources University, Sari, Iran

² Department of Agronomy, Genetics and Agricultural Biotechnology Institute of Tabarestan, Sari Agricultural Sciences and Natural Resources University, Sari, Iran

³ Genetics and Agricultural Biotechnology Institute of Tabarestan, Sari Agricultural Sciences and Natural Resources University, Sari, Iran

(Received: 2023/12/12-Accepted: 2024/04/30)

Abstract

Salinity is one of the most important and widespread abiotic stresses that limit the growth of crops and productivity. To evaluate the yield and salt tolerance indices in contrast rice genotypes, a factorial experiment was conducted based on a randomized complete block design with three replications in 2022. The treatments included three levels of salinity stress (control, 4 and 8 dS.m⁻¹) and 17 genotypes, including two sensitive and two tolerant check cultivars and 13 advanced (M10) mutant lines. Also, the investigated traits in this study were stress tolerance index (STI), stress susceptibility index (SSI), tolerance index (TOL), geometric mean productivity (GMP), mean productivity index (MP), and harmonic mean (HM) along with rice paddy yield (PY) in both normal and salt stress conditions. The results showed that salinity stress at both levels of 4 and 8 dS.m⁻¹ markedly reduced PY in all the studied genotypes. The lowest values of STI (0.04) and TOL (-11.79) were recorded in IR29 and Deilamani cultivars, respectively. When the cultivars were grown at 4 dS.m⁻¹ of salt stress, the MP10 genotype was superior in terms of GMP (1.32), MP (16.83), and HM (16.05) indices. By comparison, at salinity stress of 8 dS.m⁻¹ the highest values for GMP, MP and HM indices were obtained in the MP10, MP6 and MP10 genotypes with 1.21, 8.32 and 5.42, respectively. Cluster analysis at salinity levels of 4 and 8 dS.m⁻¹ showed that the studied mutants have a significant variation in stress tolerance indices. The MP10 mutant line achieved the highest PY, which was close to the Deilamani tolerant check cultivar when grown at under 8 dS.m⁻¹ of salinity stress. Also, this promising line recorded the highest value of tolerance indices in both salinity levels of 4 and 8 dS.m⁻¹. Therefore, the advanced mutant line of MP10 could be recommended for further research on salinity stress tolerance mechanisms.

Keywords: Mutant, Rice, Salinity stress, Tolerance indices

Introduction

The stress caused by the salinity of soil and water is one of the most important abiotic stresses in agricultural systems that exist in wide areas of the world (Ahmad *et al.*, 2018; Hosseini *et al.*, 2019; Hosseini *et al.*, 2020; Khalvandi *et al.*, 2019). Around 340 to 900 million hectares of land are faced with salinity worldwide. Also, many parts of Iran have the problem of salinity and drainage. Almost 20% of the total area of Iran, totaling 25 million hectares, is adversely affected by different degrees of salinity (FAO, 2007; Munns, 2002). Salinity has significantly affected plants through ionic toxicity, osmotic stress, imbalance of nutrients, and extensive changes in the synthesis of biochemical compounds (Abdel Latif *et al.*, 2021; Khan, 2018). Also, salinity

leads to a consequence series of morphological, physiological, biochemical, and molecular changes that hurt the growth and plant productivity (Ghonaim *et al.*, 2021; Munns, 2002; Munns *et al.*, 2020).

95% of the rice (*Oryza sativa* L.) is now cultivated in the two provinces of Mazandaran and Gilan (Jafari Rad *et al.*, 2014). The statistics show that between 200 and 300 thousand hectares of rice fields in Guilan, Mazandaran, and Golestan provinces are threatened by salinity (Mirdar Mansouri, 2012). Among different solutions, rice plant improvement can be more promising and significant compared to other soil improvement processes. By introducing salt-tolerant rice cultivars and identifying effective traits, millions of hectares of saline and non-cultivable land can be

*Corresponding Author, Email: h.pirdashti@sanru.ac.ir

properly exploited (Kibria *et al.*, 2017). Studies have shown that the rice plant is tolerant to salinity during the germination stage but shows the highest sensitivity to salinity during the seedling and flowering stages (Hussain *et al.*, 2017). Therefore, it is necessary to identify and introduce salt-tolerant lines using different breeding approaches.

Mutation breeding is a shortcut method to improve many important agricultural traits, such as tolerance to abiotic stresses, resistance to diseases, improved quality, and marketability (Negrao *et al.*, 2017). Therefore, mutation induction is an important method to increase the mutant frequency (Da Luz *et al.*, 2016; Majidi and Amiri Fahlani, 2016). More than 3402 mutant varieties have been introduced worldwide, of which 64% have been improved by gamma rays (Musavizadeh *et al.*, 2018). Oladi *et al.* (2014) used the International Rice Research Institute (IRRI) standard to evaluate 42 rice mutant lines with Sang-e-Tarom, Nemat, and Hashemi in soil with a salinity of 7 dS.m⁻¹. Cluster analysis classified 35% of the lines in the tolerant group, 57% in the moderate tolerance group, and 8% in the sensitive group. Meanwhile, stress resistance indices are also used to check the response of different cultivars to salinity stress (Hossain *et al.*, 1990). Selection based on the stress susceptibility index (SSI) often resulted in selecting genotypes with relatively low performance under normal conditions and high performance under stress conditions (Farshadfar and Sutka, 2003). In general, cultivars with SSI greater than one are considered sensitive. Rosielle and Hamblin (1981) introduced the tolerance index (TOL) and mean productivity (MP). Then, stress tolerance indices (STI) and geometric mean productivity (GMP) were proposed by Fernandez (1992) to identify genotypes that produce optimal yield under both normal and stressful conditions. Fernandez (1992) introduced the STI as a suitable index to distinguish genotypes to achieve high performance under stress conditions. Accordingly, GMP and STI indicators were introduced as the best indicators and the most suitable rice genotypes (Erfani *et al.*, 2012). Also, Asadi *et al.* (2012) introduced STI and GMP as the most appropriate criteria for determining wheat tolerance and achieving higher yields in both saline and non-saline conditions. Various studies applied salinity tolerance indices and the correlation between them to select the salt-tolerant cultivars (e.g., Jafari Rad *et al.*, 2014; Mirdar Mansori *et al.*, 2011). Since these mutant lines were improved in a breeding program for tolerance to salinity (Oladi *et al.*, 2020), the purpose of the present research is to evaluate the performance of the advanced generation of rice mutant lines (M10) to salt stress conditions using various tolerance indices.

Materials and methods

The current research was carried out as a factorial experiment based on a randomized complete block design with three replications at the Genetics and

Agricultural Biotechnology Institute of Tabarestan (GABIT) located in the Sari Agricultural Sciences and Natural Resources University (SANRU) in 2022. In this experiment, 17 rice genotypes including 13 advanced mutant lines (M10 generation), were used which had been obtained by gamma-ray irradiation from Cobalt spring 60 from Sang-e-Tarom (P1), Hashemi (P3) and Khazar (P18) varieties (Oladi *et al.*, 2019), (Table 1). Two international (IR29) and naive (Sepidrood) sensitive controls were also used along with two international (Nonabukra) and native (Deylamani) tolerant controls. Salinity stress using NaCl solutions was imposed at three levels including control (no salinity stress) and 4 and 8 dS.m⁻¹.

First, the genotype seeds were disinfected with fungicide and then transferred to the germinator. The seeds were kept in the dark for 48 hours at a temperature of 25 C until they germinated. Then the germinated seeds were exposed to the optimum light for initial growth and, after that, planted in a seed tray filled with paddy soil. Seedlings with three leaves (BBCH: 13) from each genotype were transferred to the pots with a capacity of seven kilograms of soil (with an opening diameter of 26 cm and a height of 24 cm) and planted at a distance of 20×20 cm. After the establishment of the plants (about a week after transplanting), saline treatments will be applied. The amount of NaCl needed to apply each of the salinity levels will be calculated using Equation 1 (Hasheminia *et al.*, 1997).

$$TDS = 0.6 EC$$

Where EC is electrical conductivity and TDS is total dissolved solids.

At the time of fully ripening (BBCH: 89), the PY was determined in terms of grams per plant based on the IRRI standard (SES, 2013) in the stress (Y_s) and normal or potential (Y_p) conditions. After harvesting, tolerance indices to salinity stress (Table 2) were calculated using the Y_p and Y_s and the average yield of all genotypes in non-stressed (\bar{Y}_p) and stressed conditions (\bar{Y}_s).

Finally, the data obtained from the experiment were analyzed with SAS statistical software version 9.2, and the correlation coefficient and cluster analysis (Ward method) between indicators were calculated with SPSS software version 16. Duncan's multiple range test ($\alpha=0.05$) was used to compare the mean yields of genotypes in different treatments.

Results and discussion

The results of ANOVA related to all studied indices in different rice genotypes under salinity stress are shown in Table 3. Based on the obtained results, it was observed that the simple effect of salinity and genotype, as well as their interaction effect, was highly significant for all tolerance indices. Similarly, Afkhami *et al.* (2021) showed a considerable difference between rice genotypes when grown at both 4 and 8 dS.m⁻¹ of salinity. Also, Izaddoost *et al.* (2013) and Sabouri *et al.* (2008) reported a significant difference among

Table 1. The list of studied mutants along with native and international sensitive and tolerant controls

Row	Lines code	Abbreviated line code	Row	Lines code	Abbreviated line code
1	M10-P1-1-1-1-4-1	MP1	10	M10-P3-4-7-1-1-1	MP10
2	M10-P1-4-2-1-2-1	MP2	11	M10-P18-1-4-2-1-1-1	MP11
3	M10-P1-7-1-1-1-1	MP3	12	M10-P18-1-4-3-3-1-1-1	MP12
4	M10-P1-7-1-1-2-1	MP4	13	M10-P18-1-7-3-4-2-1-1	MP13
5	M10-P3-4-4-6-1-1	MP5	14	Nonabukra (International tolerant control)	Nonabukra
6	M10-P3-4-4-7-1-1	MP6	15	Sepidrood (Native sensitive control)	Sepidrood
7	M10-P3-4-4-7-1-2	MP7	16	Deilamani (Native tolerant control)	Deilamani
8	M10-P3-4-4-10-11	MP8	17	IR29 (International sensitive control)	IR29
9	M10-P3-4-5-7-1-1	MP9			

M = Mutant, P1 = Sang-e Tarom, P3 = Hashemi, P18 = Khazar

Table 2. The calculated tolerance indices used in the experiment

Row	Index name	Abbreviations	Relation	References
1	Stress Tolerance Index	STI	$STI = \frac{YP \times YS}{(YP)^2}$	Fernandez (1992)
2	Stress Susceptibility Index	SSI	$SSI = \frac{1 - \frac{YS}{YP}}{1 - \frac{YS}{YP}}$	Fisher and Maurer (1978)
3	Tolerance Index	TOL	$TOL = YP - YS$	Rosiel and Hamblin (1981)
4	Geometric mean productivity	GMP	$GMP = \sqrt{YS \times YP}$	Fernandez (1992)
5	Mean productivity index	MP	$MP = \frac{YP + YS}{2}$	Rosiel and Hamblin (1981)
6	Harmonic mean	HM	$HM = \frac{2(YP \times YS)}{YP + YS}$	Fernandez (1992)

Table 3. Variance analysis of the salinity effect on salt tolerance indices at different rice genotypes

Source of Variation	df	STI	SSI	TOL	GMP	MP	HM
Replication	2	0.00563	0.0338	0.08237	0.00010	0.4560	1.0680
Salinity (S)	1	40.478**	896.797**	2403.701**	0.354**	600.925**	21633.31**
Genotypes (G)	16	2.395**	23.940**	104.603**	0.0269**	68.107**	666.66**
S×G	16	1.5637**	30.4965**	49.207**	0.00149**	12.301**	442.865**
Error	66	0.00014	0.00971	0.00174	1.480	0.00043	0.015730
CV (%)	-	1.48	2.66	1.66	0.10	0.27	0.60

** : Significant at 1% levels

Stress tolerance index (STI), stress susceptibility index (SSI), tolerance index (TOL), geometric mean productivity (GMP), mean productivity index (MP), and harmonic mean

genotypes regarding various indices.

The results of the average comparison between the studied different genotypes based on STI, SSI, TOL, GMP, MP, and HMP indices under the salinity stress of 4 dS.m⁻¹ have been shown in Table 4. The highest value for the STI (3.5) was obtained for the MP10 genotype, while the lowest value (0.04) was obtained for the IR29 cultivar. Also, two genotypes of MP11 and MP8, which had the lowest values of stress susceptibility index (SSI), respectively, are among the tolerant cultivars. According to this index, the sensitive and tolerant genotypes can be determined regardless of their performance potential (Fischer and Maurer, 1978). Also, the lowest stress tolerance index (TOL), whose low values indicate the relative tolerance of cultivars, was related to Deilamani cultivar with -11.79. The highest values for GMP and MP indices were obtained in the MP10 genotype, with 1.32 and 16.83,

respectively. Selection based on the MP index allows the choice of genotypes with high potential yield (Fernandez, 1992). Based on the comparison results, the highest amount of HM (16.05) was related to the MP10 genotype, and the lowest amount (1.72) was recorded in the IR29 genotype. Since the high numerical values of MP, GMP, STI, and HM indices indicate relative tolerance to stress (Table 4), the MP10 line has the highest value in all these indices. This line can be introduced as a tolerant line in salinity of 4 dS.m⁻¹. Aminpanah *et al.* (2018) also selected the STI, MP, GMP, and HM as the best indices and used them to introduce stress-tolerant genotypes with high yield under both stress and non-stress conditions.

The results of the average comparison between the different studied genotypes based on STI, SSI, TOL, GMP, MP, and HMP indices under the salinity stress of 8 dS.m⁻¹ are shown in Table 5. The average comparison

Table 4. Mean comparison of salt tolerance indices for different rice genotypes at salt stress of 4 dS m⁻¹

Genotypes	Tolerance Indices					
	STI	SSI	TOL	GMP	MP	HM
MP1	1.03 h	4.72 g	0.06 h	1.24 g	8.93 j	8.93 h
MP2	1.01 i	4.42 h	0.79 e	1.24 g	8.79 k	8.77 i
MP3	2.26 f	8.70 c	-9.72 p	1.29 e	14.08 d	12.40 e
MP4	3.14 b	6.79 e	-6.82 l	1.31 b	15.93 b	15.20 b
MP5	0.26 m	8.78 c	-3.35 j	1.16 k	4.79 o	4.20 m
MP6	2.51 d	4.26 h	1.94 d	1.30 d	13.97 e	13.90 c
MP7	1.79 g	4.65 g	0.31 g	1.27 f	11.75 h	11.75 f
MP8	0.08 n	1.98 k	3.64 b	1.09 l	3.12 p	2.05 o
MP9	2.64 c	7.10 d	-7.02 m	1.30 c	14.70 c	13.87 c
MP10	3.50 a	6.80 e	-7.23 n	1.32 a	16.83 a	16.05 a
MP11	0.48 k	1.81 k	10.25 a	1.19 i	7.97 l	4.68 l
MP12	1.78 g	3.91 i	2.94 c	1.27 f	11.82 g	11.63 g
MP13	0.27 m	17.49 a	-7.41 o	1.16 k	5.89 m	3.55 n
Nonabukra	0.35 l	5.87 f	-1.37 i	1.17 j	5.26 n	5.17 k
Sepidrood	2.30 e	6.74 e	-5.73 k	1.29 e	13.63 f	13.03 d
Deilamani	0.83 j	15.66 b	-11.79 q	1.23 h	9.95 i	6.45 j
IR29	0.04 o	3.53 j	0.69 f	1.05 m	1.79 q	1.72 p

In each column, means with similar letters were not significantly different ($P \leq 0.05$).

Table 5. Mean comparison of salt tolerance indices for rice genotypes at salt stress of 8 dS.m⁻¹

Genotypes	STI	SSI	TOL	GMP	MP	HM
MP1	0.13 j	0.84 ef	7.85 j	1.12 h	5.04 i	2.00 i
MP2	0.13 j	0.85 de	8.04 i	1.12 h	5.13 h	1.99 i
MP3	0.15 h	0.83 g	8.02 i	1.13 g	5.22 g	2.23 g
MP4	0.18 g	0.89 b	11.50 d	1.14 f	6.78 cd	2.04 h
MP5	0.04 l	0.59 k	2.21 m	1.06 k	2.05 m	1.58 l
MP6	0.32 c	0.86 d	13.25 a	1.17 b	8.28 a	3.04 d
MP7	0.14 i	0.90 b	10.95 e	1.12 g	6.45 e	1.78 k
MP8	0.02 n	0.90 b	4.53 k	1.03 m	2.67 k	0.76 o
MP9	0.33 b	0.75 i	8.89 h	1.17 b	6.74 d	3.83 c
MP10	0.58 a	0.69 j	9.80 f	1.21 a	8.27 a	5.42 a
MP11	0.09 k	0.94 a	12.5 b	1.10 i	6.83 c	1.08 m
MP12	0.23 d	0.87 c	11.87 c	1.15 c	7.36 b	2.47 f
MP13	0.04 l	0.12 l	0.55 o	1.06 j	1.86 n	1.84 j
Nonabukra	0.03 m	0.84 ef	3.99 l	1.05 l	2.55 l	1.03 n
Sepidrood	0.20 e	0.83 fg	9.25 g	1.14 d	6.16 f	2.57 e
Deilamani	0.19 f	-0.07 m	0.35 p	1.14 e	3.85 j	3.84 b
IR29	0.01 o	0.76 h	1.75 n	0.99 n	1.24 o	0.69 p

In each column, means with similar letters were not significantly different test ($P \leq 0.05$).

results showed that the highest value of STI was obtained for genotype MP10 and the lowest for IR29 with 0.58 and 0.011, respectively. The highest values for MP and GMP indices were obtained in genotypes MP6 and MP10 with 8.32 and 1.21, respectively. For the HMP index, the highest value was obtained in the MP10 genotype at 5.42, while the lowest value was recorded in the IR29 genotype at 0.69. Similarly, higher values of STI, GMP, MP, and HM indices in seven-day-old rice seedlings resistant to salt stress (Hosseini *et al.*, 2012) and also in salt-resistant genotypes of rice at the seedling stage (Mirdarmansouri *et al.*, 2012; Izaddoost *et al.*, 2013) was reported earlier. The genotype with high GMP and MP and less TOL is more tolerant of stress (Saberi *et al.*, 2015; Rezaei *et al.*, 2010; Jabbari *et al.*, 2008). The best value of SSI index related to the Deilamani genotype was obtained with -0.078. The SSI

indicates that if a genotype performs better in both stress and non-stress conditions, but shows a large percentage of changes, it is not identified as a tolerant genotype. For this reason, selection based on this index reduces the performance potential in suitable and stress-free environments (Schneider *et al.*, 1997). Also, the highest value of the TOL index related to MP10 genotype while the lowest one was for the Deilamani cultivar with values of 13.25 and 0.39, respectively. Selection based on the TOL index often leads to the selection of genotypes that have relatively low performance under normal conditions. In the other words, the TOL cannot distinguish genotypes that are tolerant to stress conditions (Jafari Rad, 2014).

Based on the cluster results using Ward's minimum variance method and Euclidean distance square measure, the studied genotypes were placed in four

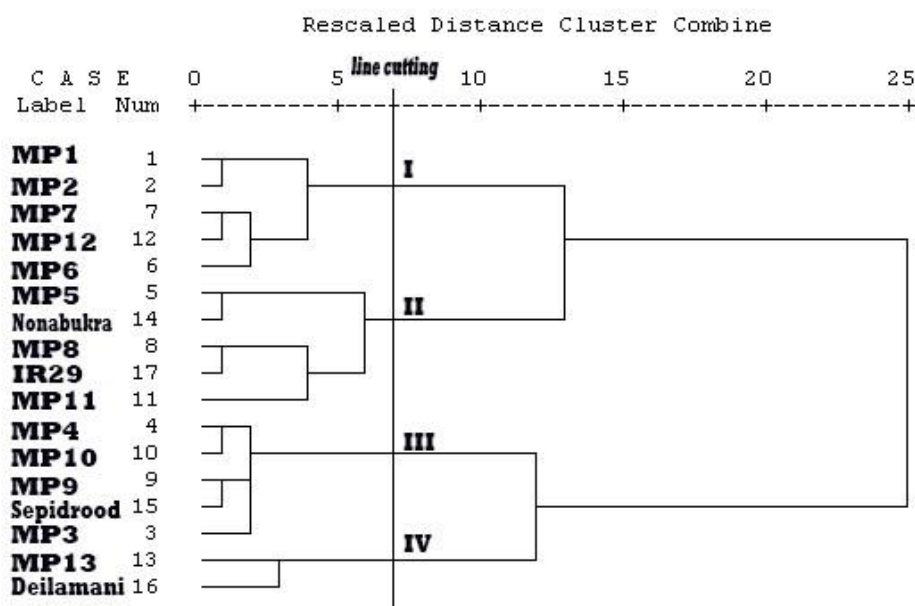

Figure 1. Dendrogram obtained from cluster analysis using Ward's method based on all studied genotypes under salinity stress of 4 dS.m⁻¹

Table 6. The results of the discriminant function for the validity of the clustering of rice genotypes at a salinity of 4 dS.m⁻¹

Group	Group Membership				TOTAL
	1	2	3	4	
Original	1	5	0	0	0
	2	0	5	0	0
	3	0	0	5	0
	4	0	0	0	2
Percent	1	100	0	0	0
	2	0	100	0	0
	3	0	0	100	0
	4	0	0	0	100
					100

100.0% of originally grouped cases were correctly classified

groups at the salinity stress level of 4 dS.m⁻¹ (Figure 1). To ensure the accuracy of the groupings obtained from the analysis method, a cluster discriminant function was used (Table 6). Nonabukra and IR29 cultivars (internationally sensitive and tolerant, respectively) were included in one group. The Sepidrood (native sensitive) variety was placed in the second group, and the Deilamani (native tolerant) variety was placed in the third group. The dendrogram obtained from the evaluation of salinity tolerance at a salinity level of 4 dS.m⁻¹ by Sabouri *et al.* (2008) showed that all studied genotypes of rice were placed in three separate groups. The discriminant function showed that all the genotypes were correctly grouped, and the success rate of the whole discriminant function was 100%. The success rate indicates how successful the discriminant function was in grouping or classifying between groups (Safari *et al.*, 2007).

Cluster analysis divided the studied genotypes into

three separate groups at the salt stress level of 8 dS.m⁻¹ (Figure 2). A discriminant function was used to ensure the accuracy of the groupings obtained from the cluster analysis (Table 7). Deilamani, Nonabukra, and IR29 cultivars were placed in the third group, and the Sepidrood cultivar (native sensitive check) was placed in the first group. Similar results were reported in another study by Izaddoost *et al.* (2013) in 8 dS.m⁻¹ of salt stress in different rice genotypes. Cluster analysis is usually used as a multivariate statistical method to separate and group contrast genotypes (Hossain *et al.*, 1990; Li *et al.*, 2021; Mazlomi *et al.*, 2020).

The results of the correlation coefficient between the various studied indicators under the salinity stress of 4 dS.m⁻¹ in different rice genotypes are shown in Table 7. Based on the results, it was observed that PY had a positive and significant correlation with STI, HMP, MP, and GMP indices. STI index also positively and significantly correlated with GMP, MP, and HMP

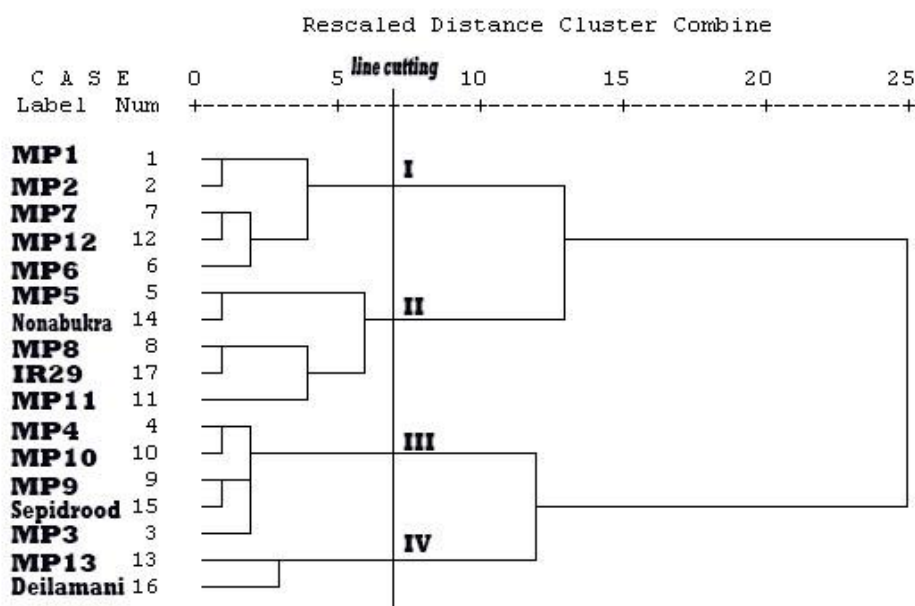

Figure 2. Dendrogram obtained from cluster analysis using Ward's method based on all studied genotypes under salinity stress of 4 dS m⁻¹

Table 7. Correlation coefficient of salinity stress indices and PY in 4 and 8 dS.m⁻¹ conditions

	STI	SSI	TOL	GMP	MP	HM	Yield
4 dS.m ⁻¹							
STI	1						
SSI	-0.05	1					
TOL	-0.38	-0.77 **	1				
GMP	0.90 **	0.04	-0.34	1			
MP	0.96 **	0.04	-0.39	0.96 **	1		
HMP	0.97 **	-0.07	-0.33	0.95 **	0.97 **	1	
Yield	0.87 **	0.38	-0.74 **	0.86 **	0.91 **	0.86 **	1
8 dS.m ⁻¹							
STI	1						
SSI	0.03	1					
TOL	0.51 *	0.69 **	1				
GMP	0.87 **	0.04	0.66 **	1			
MP	0.78 **	0.40	0.91 **	0.89 **	1		
HMP	0.92 **	-0.31	0.23	0.84 **	0.59 *	1	
Yield	0.73 **	-0.61 **	-0.057	0.67 **	0.35	0.93 **	1

* and **: Significant at 5 and 1% levels, respectively

indices as well as GMP index with MP and HMP and PY. Also, the TOL index was negatively and significantly correlated with PY and SSI. The results of this research are similar to the results of Yarahmadi *et al.* (2020) in wheat and Jafari Rad *et al.* (2014) in rice genotypes, which showed that tolerance indices such as STI, GMP, HM, MP, and YI had a positive and significant correlation with PY in both normal and stress conditions.

Table 7 displays the correlation coefficients between the different studied indicators in various rice genotypes under salinity stress of 8 dS.m⁻¹. There was a positive and significant correlation between PY with STI, GMP. Also, HMP indices and STI index with TOL, GMP, MP showed a positive and significant correlation. Similar

results was observed between HMP indices and SSI index with TOL, TOL index with GMP and MP indices and MP index with HMP. The SSI index had a negative and significant correlation with the PY. The correlation coefficient between the salinity tolerance indices at the level of 8 dS.m⁻¹ in the assessment of salinity tolerance in rice cultivars and lines by Izaddoost *et al.* (2013) showed that STI index with TOL, GMP, and MP indices and TOL index with STI, MP, and GMP as well as GMP index had a positive and significant correlation with STI, TOL, MP and HM indices and then MP with STI, TOL and GMP indices as well as STI and GMP indices. The correlation coefficient between the various studied indices under the salinity stress of 8 dS.m⁻¹ in different genotypes of rice which was investigated by

Table 8. Mean comparison of PY (g/plant) of different rice genotypes under control and salt stress conditions

Genotypes	Control	4 dS.m ⁻¹	8 dS.m ⁻¹
MP1	8.96 ^k	8.91 ^k	1.134 ⁱ
MP2	9.19 ^j	8.41 ^l	1.127 ⁱ
MP3	9.22 ⁱ	18.95 ^c	1.27 ^h
MP4	12.52 ^e	19.36 ^b	1.11 ⁱ
MP5	3.11 ^o	6.47 ^m	1.07 ^j
MP6	14.94 ^a	13.01 ^g	1.70 ^d
MP7	11.91 ^f	11.61 ^h	0.93 ^k
MP8	4.94 ^l	1.31 ^p	0.42 ⁿ
MP9	11.19 ^g	18.22 ^d	2.32 ^c
MP10	13.21 ^c	20.46 ^a	3.42 ^b
MP11	13.10 ^d	2.86 ^o	0.57 ^m
MP12	13.29 ^b	10.35 ⁱ	1.37 ^g
MP13	2.18 ^p	9.27 ^j	1.59 ^e
Nonabukra	4.57 ^m	5.96 ⁿ	0.59 ^l
Sepidrood	10.76 ^h	16.17 ^e	1.47 ^f
Deilamani	4.05 ⁿ	15.85 ^f	3.66 ^a
IR29	2.14 ^q	1.45 ^p	0.42 ⁿ

In each column, means with similar letters were not significantly different based on Duncan's multiple range test ($P \leq 0.05$).

Afkhami *et al.* (2021) showed that the HM index showed positive and significant correlation with MP, GMP, and STI indices and STI index with MP and GMP as well as SSI index with TOL and GMP index with MP.

According to the findings, the salinity stress of 4 dS.m⁻¹ had a negative effect only in four genotypes of MP6, MP8, MP11 and MP12. However, the salinity of 8 dS.m⁻¹ reduced the PY of all the studied genotypes except the Deilamani cultivar, which was considered a native tolerant control. When the salinity of plots reached 8 dS.m⁻¹, the Deilamani cultivar showed the lowest (9.6%), and the MP11 showed the highest reduction (95%) compared to the normal conditions. In the control conditions, the highest and the lowest PY was recorded in MP6 (14.94 g/plant) and IR29 (2.14 g/plant). In contrast, at 4 dS.m⁻¹ of salinity conditions, MP10 (20.46 g/plant) and IR29 (1.45 g/plant), and at 8 dS.m⁻¹ of salt stress, Tarem Deilamani (3.66 g/plant) and IR29 (0.42 g/plant) and MP8 (0.42 g/plant) showed the maximum and minimum PY, respectively (Table 8). Among the genotypes, at a salinity level of 8 dS.m⁻¹, PY of MP10 was found to be close to the Tarem Deilamani salt-tolerant cultivar. This result shows the high potential of seed production of this cultivar in saline

conditions. Hasamuzzaman *et al.* (2009) observed that although different rice cultivars respond differently to salinity stress, the PY of rice cultivars decreased with increasing salinity levels. The decrease in PY of rice cultivars under salt conditions has been previously reported by Saeedzadeh *et al.* (2018), Jafari Rad *et al.* (2014), Biabani *et al.* (2012) and Gain *et al.* (2004).

Conclusion

The results of this research clearly showed that salinity stress at both levels of 4 and 8 dS.m⁻¹ markedly reduced PY in all studied genotypes. According to the yield of advanced mutant lines at the salinity level of 8 dS.m⁻¹ the MP10 line yield was close to that of the Deilamani tolerant control. Based on the results of the tolerance indices, the MP10 line showed the highest value in both salinity levels of 4 and 8 dS.m⁻¹, therefore, could be introduced as a superior line for further and supplementary research.

Acknowledgments

The authors gratefully thank GABIT and SANRU for their support grants.

References

- Abdel Latef, A. A., Tahjib-Ul-Arif, M., & Rhaman, M. S. (2021). Exogenous auxin-mediated salt stress alleviation in faba bean (*Vicia faba* L.). *Agronomy*, 11(547), 1-16. <https://doi.org/10.3390/agronomy11030547>
- Afkhami Ghadi, A., Habibzadeh, F., & Hosseini, S. J. (2021). Evaluation of rice genotypes from crossing based on salinity stress tolerance indices. *Journal of Crop Breeding*, 3(39), 108-121. <https://doi.org/10.52547/jcb.13.39.108>
- Ahmad, P., Ahanger, M. A., Alyemini, M. N., Wijaya, L., Alam, P., & Ashraf, M. (2018). Mitigation of sodium chloride toxicity in *Solanum lycopersicum* L. by supplementation of jasmonic acid and nitric oxide. *Journal of Plant Interactions*, 13(1), 64-72. <https://doi.org/10.1080/17429145.2017.1420830>
- Aminpanah, H., Sharifi, P., & Ebadi, A. A. (2018). Evaluation of drought response in some rice mutant lines using stress tolerance indices. *Iranian Journal of Field Crops Research*, 16(1), 191-202. <https://doi.org/10.22067/gsc.v16i1.61793>

- Asadi, M., Mohammadi-Nejad, G., Golkar, P., Naghavi, H., & Nakhoda, B. (2012). Assessment of salinity tolerance of different promising lines of bread wheat (*Triticum aestivum* L.). *Advances in Applied Science Research*, 3(2), 1117-1121.
- Biabani, A., Sabouri, H., & Nakhzari, A. (2012). Study of yield components of rice cultivars under salinity stress conditions. *Journal of Plant Production*, 19(4), 173-186.
- Da Luz, V. K., da Silveira, S. F. S., da Fonseca, G. M., Groli, E. L., Figueiredo, R. G., & Baretta, D. (2016). Identification of variability for agronomically important traits in rice mutant families. *Bragantia*, 75, 41-50. <https://doi.org/10.1590/1678-4499.283>
- Erfani, F., Shokrpour, M., & Erfani, A. (2012). Evaluation of drought tolerance in rice varieties using yield-based indices at vegetative and reproductive stage. *Journal of Agricultural Science and Sustainable Production*, 22(4), 135-147.
- FAO. (2007). FAO Land and Plant Nutrition Management Service. Available online at <http://www.fao.org>.
- Farshadfar, E. & Sutka J. (2003). Multivariate analysis of drought tolerance in wheat substitution lines. *Cereal Research Communications*, 31(1), 33-40. <https://doi.org/10.1007/BF03543247>
- Fernandez, G. C. J. (1992). Effective selection criteria for assessing stress tolerance. In: Proceedings of the International Symposium on Adaptation of Vegetables and Other Food Crops in Temperature and Water Stress. (ed. Kuo, G.) Pp. 257-270. Tainan, Taiwan.
- Fischer, R. & Maurer, R. (1978). Drought resistance in spring wheat cultivars. I. Grain yield responses. *Crop and Pasture Science*, 29, 897-912. <https://doi.org/10.1071/AR9780897>
- Gain, P., Mannan, M. A., Pal, P. S., Maheb Hossain, M., & Parvin, S. (2004). Effect of salinity on some yield attributes of rice. *Pakistan Journal of Biological Science*, 7(5), 760-762.
- Ghonaim, M. M., Mohamed, H. I., & Omran, A. A. (2021). Evaluation of wheat (*Triticum aestivum* L.) salt stress tolerance using physiological parameters and retrotransposon-based markers. *Genetic Resources and Crop Evolution*, 68(1), 227-242. <https://doi.org/10.1007/s10722-020-00981-w>
- Hasamuzzaman, M., Fujita, M., Islam, M. N., Ahamed, K. U., & Nahar, K. (2009). Performance of four irrigated rice varieties under different levels of salinity stress. *International Journal of Integrative Biology*, 6(2), 85-90.
- Hasheminia, S., Kouchaki, A., & Ghahraman, N. (1997). Utilization of Saline Water in Sustainable Agriculture. Mashhad University Jihad. Mashhad.
- Hossain, A., Sears, R., Cox, T., & Paulsen, G. (1990). Desiccation tolerance and its relationship to assimilate partitioning in winter wheat. *Crop Science*, 30(3), 622-627. <https://doi.org/10.2135/cropsci1990>
- Hosseini, S. J., Tahmasebi-Sarvestani, Z., Pirdashti, H., Modarres Sanavi, S. A. M., Mokhtassi-bidgoli, A., & Hazrati, S. (2019). Study of diversity and estimation of leaf area in different mint ecotypes using artificial intelligence and regression models under salinity stress conditions. *Journal of Crop Breeding*, 11(32), 59-73. <https://doi.org/10.29252/jcb.11.32.59>
- Hosseini, S. J., Tahmasebi-Sarvestani, Z., Pirdashti, H., Modarres-Sanavy, S. A. M., Mokhtassi-Bidgoli, A., Hazrati, S., & Nicola, S. (2020). Assessment of salinity indices to identify mint ecotypes using intelligent and regression models. *International Journal of Horticultural Science and Technology*, 7(2), 119-137. <https://doi.org/10.22059/ijhst.2020.294728.330>
- Hussain, S., Zhang, J. H., Zhong, C., Zhu, L. F., Cao, X. C., Yu, S. M., & Jin, Q. Y. (2017). Effects of salt stress on rice growth, development characteristics, and the regulating ways: A review. *Journal of Integrative Agriculture*, 16(11), 2357-2374. [https://doi.org/10.1016/S2095-3119\(17\)61683-6](https://doi.org/10.1016/S2095-3119(17)61683-6)
- Izaddoost, H., Samizadeh, H., Rabiei, B., & Abdollahi, S. H. (2013). Evaluation of salt tolerance in rice (*Oryza sativa* L.) cultivars and lines with emphasis on stress tolerance indices. *Journal Cereal Research*. 3(3), 167-180. <https://doi.org/20.1001.1.22520163.1392.3.3.1.2>
- Jafari Rad, S., Zavareh, M., Khaledian, M. M., & Rezai, M. (2014). Evaluation of the tolerance of different genotypes of rice to irrigation water salinity. *Journal of Production and Processing of Agricultural and Horticultural Products*, 17(5), 1-12.
- Jabbari, H., Akbari, G. A., Daneshian, J., Alahdadi, I., & Shahbazian, N. (2008). Utilization ability of drought resistance indices in sunflower (*Helianthus annuum* L.) hybrids. *Electronic Journal of Crop Production*, 1(4), 1-17.
- Khan, F. (2018). Salinity stress phenotyping for soybean (*Glycine max* L.) for Middle East Asia. *Legume Research*, 41(4), 551-556. <https://doi.org/10.18805/LR-375>
- Khalvandi, M., Amerian, M., Pirdashti, H., Keramati S., & Hosseini, J. (2019). Essential oil of peppermint in symbiotic relationship with *Piriformospora indica* and methyl jasmonate application under saline condition. *Industrial Crops and Products*, 127, 195-202. <https://doi.org/10.1016/j.indcrop.2018.10.072>
- Kibria, M. G., Hossain, M., Murata, Y., & Hoque, M. A. (2017). Antioxidant defense mechanisms of salinity tolerance in rice genotypes. *Rice Science*, 24(3), 155-162. <https://doi.org/10.1016/j.rsci.2017.05.001>
- Li, P., Yang, X., Wang, H., Pan, T., Wang, Y., Xu, Y., & Yang, Z. (2021). Genetic control of root plasticity in response to salt stress in maize. *Theoretical and Applied Genetics*, 134(5), 1475-1492. <https://doi.org/10.1007/s00122-021-03784-4>

- Majidi Mehr, A. & Amiri Fahliani, R. (2016). Analysis of the effect of salinity on chlorophyll content, chlorophyll fluorescence indices, and grain yield of some rice cultivars. *Journal of Crop Plant Breeding*, 8(18), 183-190.
- Mazlomi, H., Pirdashti, H., Ahmadpour, A., & Hosseini, S. J. (2020). Grouping of advanced wheat lines based on yield and its components. *Journal of Crop Breeding*, 12(35), 41-53. doi: 10.52547/jcb.12.35.41
- Mirdar Mansori, S. N. A., Babaeian Jelodar, N., & Bagheri, N. (2011). Evaluation of salt tolerance in Iranian rice genotypes under hydroponic medium stress tolerance and sensitivity indices. *Iranian Journal of Field Crops Research*, 9(4), 694-703. <https://doi.org/10.22067/GSC.V9I4.13278>
- Mirdarmansouri, S., Babaeian, N., & Bagheri, N. (2012). Evaluation of salt tolerance in Iranian rice genotypes in the hydroponic system based on salt stress tolerance and sensitivity attributes. *Iranian Journal of Field Crops Research*, 9(4), 694-703. <https://doi.org/10.22067/gsc.v9i4.13278>
- Munns, R. (2002). Comparative physiology of salt and water stress. *Plant, Cell and Environment*, 25, 239-250. <https://doi.org/10.1046/j.0016-8025.2001.00808.x>
- Munns, R., Passioura, J. B., Colmer, T. D., & Byrt, C. S. (2020). Osmotic adjustment and energy limitations to plant growth in saline soil. *New Phytologist*, 225(3), 1091-1096. <https://doi.org/10.1111/nph.15862>
- Musavizadeh, Z. S., Najafi-Zarini, H., Hashemi-Petroudi, S. H. R., & Kazemitabar, S. K. (2018). Assessment of proline, chlorophyll and malondialdehyde in sensitive, and tolerant rice (*Oryza sativa* L.) cultivars under salt stress conditions. *Journal of Crop Breeding*, 10, 28-35. <https://doi.org/10.29252/jcb.10.25.28>
- Negrao, S., Schmoekel, S. M., & Tester, M. (2017). Evaluating physiological responses of plants to salinity stress. *Annals of Botany*, 119, 1-11. <https://doi.org/10.1093/aob/mcw191>
- Oladi Ghadikolaie, M., Nematzadeh, G. A., Ranjbar, G. A., & Hashemi-Petroudi, S. H. (2019). Identification of rice mutants tolerant to salt stress via biochemical, quantitative, and molecular evaluation. *Journal of Plant Process and Function*. 10(42), 295-312. <https://doi.org/20.1001.1.23222727.1400.10.42.26.8>
- Oladi, M., Nemat Zadeh, Gh., Gholizadeh, A., & Afkhami, A. (2014). Evaluation of rice mutant lines resulting from gamma radiation under salinity stress. 16th National Rice Conference. Sari Agricultural Sciences and Natural Resources University, Sari.
- Oladi Ghadikolaie, M., Nematzadeh Ghara, G. A., Ranjbar, G. A., Hashemi-petroudi, S. H. (2020). Molecular validation of genes responsive to salinity stress and evaluation of their allelic diversity in mutant rice. *Journal of Plant Process and Function*, 9(5), 57-69. <https://doi.org/10.30473/cb.2020.54391.1815>
- Rezaei, M., Motamed, M. K., Yousefi, A., & Amiri, E. (2010). Evaluation of different irrigation management on rice yield. *Journal of Water and Soil*, 24(3), 565-573. <https://doi.org/10.22067/JSW.V0I0.3627>
- Rosielle, A. A. & Hamblin, J. (1981). Theoretical aspects of selection for yield in stress and non-stress environment. *Crop Science*, 21(6), 943-946. <https://doi.org/10.2135/cropsci1981>
- Saberi, M. H., Nikkhah, H. R., Tajalli, & Arazmjo, E. (2015). Effects of terminal season drought stress on yield and choosing best tolerance indices in promising lines of Barley. *Applied Field Crops Research*, 28(107), 124-132. <https://doi.org/10.22092/AJ.2015.105713>
- Sabouri, H., Rezaei, A., & Moumeni, A. (2008). Evaluation of salt tolerance in Iranian landrace and improved rice cultivars. *Journal of Science and Technology of Agriculture and Natural Resources, Water and Soil Science*, 12(45), 47-63. <https://doi.org/20.1001.1.24763594.1387.12.45.5.2>
- Safari, P., Honarnejad, R., & Esfahani, M. (2007). Assessment of genetic variation in peanuts (*Arachis hypogaea* L.) cultivars using canonical discriminant analysis. *Iranian Journal of Agricultural Research*. 6(2), 327-334. <https://doi.org/10.22067/GSC.V6I2.2439>
- Saeedzadeh, F., Taghizadeh, R., & Gurbanov, E. (2018). Investigating the effect of salinity on agronomic and biochemical traits of different rice cultivars under field conditions. *Crop Physiology Journal*, 9(36), 101-120.
- Schnider, K. A., Rosales-Serna, R., Ibarra-Perez, F., Cazares-Enriques, B., Acosta-Gallegos, J. A., Ramirez-Vallejo, P., Wassimi, N., & Kelly, J. D. (1997). Improving common bean performance under drought stress. *Crop Science*, 37, 43-50. <https://doi.org/10.2135/cropsci1997>
- Shobha-Ranni, N. (1998). The Rice Situation in Iran. International Rice Commission Newsletter.
- Yarahmadi, S., Nematzade, Gh., Sabouri, H., & Najafi Zarini, H. (2020). Relationships between drought stress tolerance indices and their use in wheat screening programs. *Journal of Crop Breeding*, 12(33), 29-41. <https://doi.org/10.29252/jcb.12.33.29>